



MVE 100/3

Three Phases - 2 poles - 3000 RPM - 50 Hz
230/400 Volt



Mechanical Features		Electric Features	
General		General	
Working Moment	1.96 kgcm	Nominal Voltage	Δ : 230 V Y : 400 V
Unbalance	0.98 kgcm	Input Power	0.1 kW
FC	98 kg	Current A Max	Δ : 0.33 A Y : 0.19 A
Bearings		Power factor	0.76
TYPE (SKF)	6202 2Z	la/ln	3
	100% 11921	Certification	
Life(h)	80%: 23283	ETL CLASS II DIV.II GROUP F,G TENV NEMA 4	T4
	50%: 95367	ATEX II 3D Ex tc IIIC Tx IP66	T 100°
Bearing Grease		Amb Temp.	-20 ≤ T°C ≤ + 40
Lube Schedule (g)			
Lube Replacement (g)			
Grease Type			

Dimensional Features (mm)

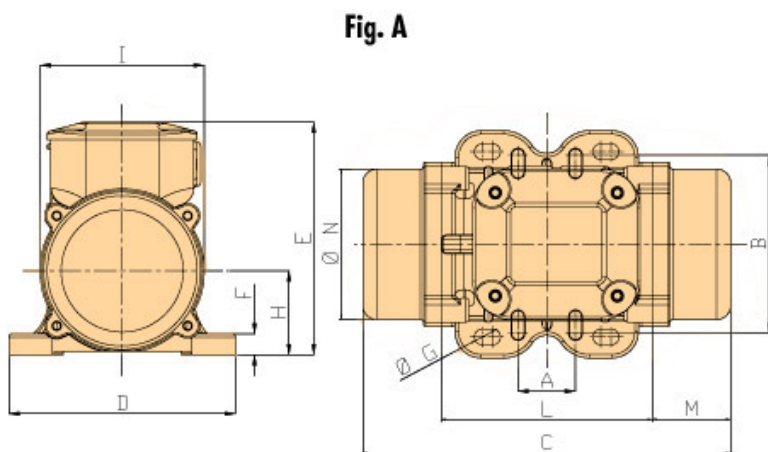

A	62-74 33
B	106 82- 102
C	211
M	45
G	9 7
holes	4 4
D	130
E	136
F	12
H	48
I	94
L	121
N	85

Clamping
Torque(Nm)

**23
9**

[[Drawings Download](#)]

Weight(kg)	Screw	Washer	Cable Type	Cable Glандe
4.2	M8 M6	8.4 x 16 6.4 x 12	4Gx1.5	M16x1,5

REV.2-03/13/2013