



MVE 700/15

Three Phases - 4 poles - 1500 RPM - 50 Hz
230/400 Volt



Mechanical Features		Electric Features	
General		General	
Working Moment	56.83 kgcm	Nominal Voltage	Δ : 230 V Y : 400 V
Unbalance	28.42 kgcm	Input Power	0.62 kW
FC	714 kg	Current A Max	Δ : 2.3 A Y : 1.32 A
Bearings		Power factor	0.83
TYPE (SKF)	6306 2Z	Ia/In	3
	100% 3063	Certification	
Life(h)	80%: 5982	ETL CLASS II DIV.II GROUP F,G TENV NEMA 4	T4
	50%: 24502	ATEX II 3D Ex tc IIIC Tx IP66	T 100°
Bearing Grease		Amb Temp.	-20 ≤ T°C ≤ + 40
Lube Schedule (g)			
Lube Replacement (g)			
Grease Type			

Dimensional Features (mm)

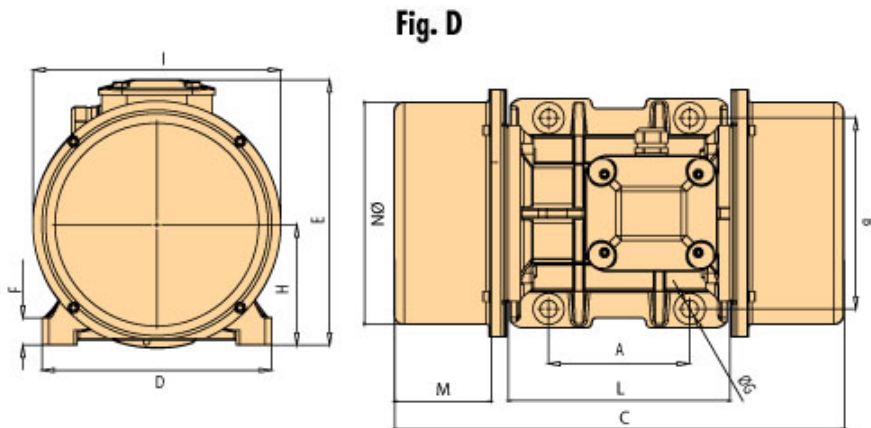

A	120
B	170
C	391
M	93
G	17
holes	4
D	208
E	210
F	22
H	94
I	180
L	205
N	170

Clamping
Torque(Nm)

185

[[Drawings Download](#)]

Weight(kg)	Screw	Washer	Cable Type	Cable Glандe
27.4	M16	17x30	4Gx2.5	M20x1,5

REV.2-03/10/2013