

---

## Lifting Station Type ABS Piranhamat 100 and 120

---

1113-00

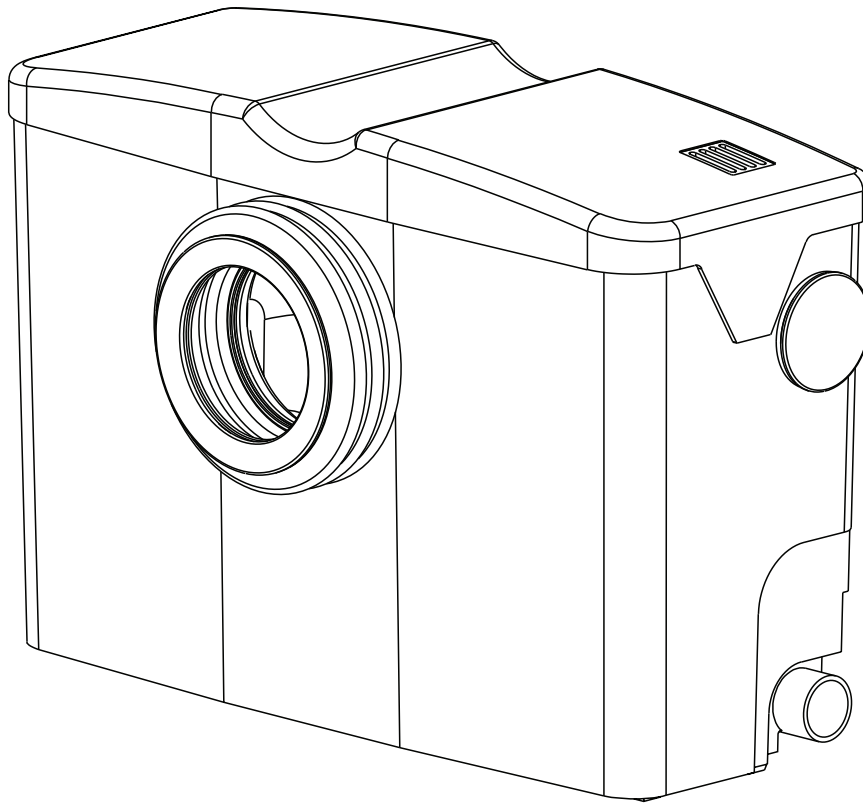

**Lifting Station Type ABS Piranhamat**100  
120**Contents**

<b>1</b>	<b>General</b> .....	<b>3</b>
1.1	Application areas.....	3
1.2	Nameplate.....	3
1.4	Legal regulations DIN and EN covering the use of lifting stations for the pumping of sewage containing faecal matter.....	4
1.5	Accessories.....	4
1.6.	Dimensions (mm).....	5
<b>2</b>	<b>Transport</b> .....	<b>5</b>
<b>3</b>	<b>Safety</b> .....	<b>5</b>
<b>4</b>	<b>Description</b> .....	<b>6</b>
4.1	Design of the Piranhamat 100/120 lifting unit.....	6
<b>5</b>	<b>Set up and installation of the Piranhamat 100/120</b> .....	<b>7</b>
5.1	Installation - inflow side.....	7
5.1.1	Installation - discharge line.....	8
5.1.2	Venting.....	9
5.1.3	Connection of hand wash basin, bidet or shower.....	9
5.2	Electrical connection.....	9
<b>6</b>	<b>Commissioning</b> .....	<b>10</b>
<b>7</b>	<b>Maintenance and service</b> .....	<b>10</b>
7.1	Maintenance of the Piranhamat 100/120 lifting unit.....	10
7.2	General maintenance hints.....	10
7.3	Steps to be taken should a fault occur.....	10
7.3.1	Piranhamat 100/120 does not work - motor makes a humming noise.....	11
7.3.2	Piranhamat 100/120 does not function and motor is silent.....	12
7.3.3	Changing the carbon filter.....	12
7.3.4	Removal of the Piranhamat 100/120.....	13

## 1 General

### 1.1 Application areas

**ATTENTION** *The maximum allowable temperature of the medium pumped is 40 °C.*

The Piranhamat 100/120 lifting unit has been specially designed for the pumping of effluent from a WC which lies below the sewer backwash level, e.g. in cellars where flow by gravity into the sewer system is not possible. They are suitable for installing either at the initial building stage or for retro-fitting to existing buildings. It is possible to connect a hand wash basin, a shower and a bidet to the unit.

**NOTE** *The Piranhamat 100/120 is recommended for single family houses only, or single rooms, and not for public or constant use.*

**NOTE** *When using a flexible hose line ensure that the connections are leak-tight at the maximum operating pressure.*

The Piranha-system shreds faecal effluent and allows it to be pumped through pipes of smaller diameter (from DN 25) or through flexible hose. It is important to note that the Piranhamat 100/120 is not a sanitary disposal unit, although it may shred particular sanitary items dropped accidentally into the WC.



The lifting unit may not be used for the collection or pumping of flammable liquids. A maximum of one toilet, one hand wash basin, and one shower tray may be connected for normal domestic use. In addition, the regulations of the Institute for Building Technology require that access to another WC above the sewer backwash level must also exist.

**NOTE** *Where the users are anonymous members of the public and usage cannot be monitored, or where more effluent sources are to be connected, we recommend the installation of the Sanimat series.*

**ATTENTION** *As with all electrical devices, this product may fail due to operating errors, absence of mains voltage, or even a technical defect. Such a failure may result in medium or water escaping. If damage may occur due to the specific usage, measures are required to avoid such damage arising. In this respect, taking account of the conditions in question, particularly use of an off-grid alarm system, use of an emergency generator, and provision of an additional and appropriately connected second unit are to be considered.*

### 1.2 Nameplate

We recommend that you record the data from the nameplate in the corresponding form below, and maintain it as a source of reference for the ordering of spare parts, repeat orders and general queries.

Always state the type, item number and serial number in all communications.

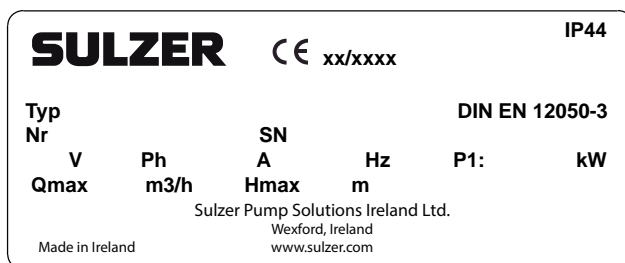

Figure 1: Nameplate

#### Legend

Type	Pump type	
Nr	Item number	
SN	Serial number	
xx/xxxx	Production date (week/year)	
	Rated voltage	V
	Rated current	A
	Frequency	Hz
P1	Rated input power	kW
Ph	Number of phases	
Qmax	Max. flow	m <sup>3</sup> /h
Hmax	Max. head	m
IP 44	Protection type	

### 1.3 Technical data

Maximum noise level  $\leq 70$ dB. This may be exceeded in certain circumstances.

Head H (m)	1.0	2.0	3.0	4.0	6.0	8.0
Flow Q (m <sup>3</sup> /h)	7.0	5.8	5.0	4.7	4.3	3.2
Flow Q (l/s)	2.0	1.6	1.4	1.3	1.2	0.9

Tank with integral pump	Discharge connection	Motorpower P1	Rated voltage	Rated current	Cable length	Weight complete
Piranhamat	DN 25 / 32	1.1 kW	220/240 V	4.7 A	2.0 m	9.0 Kg

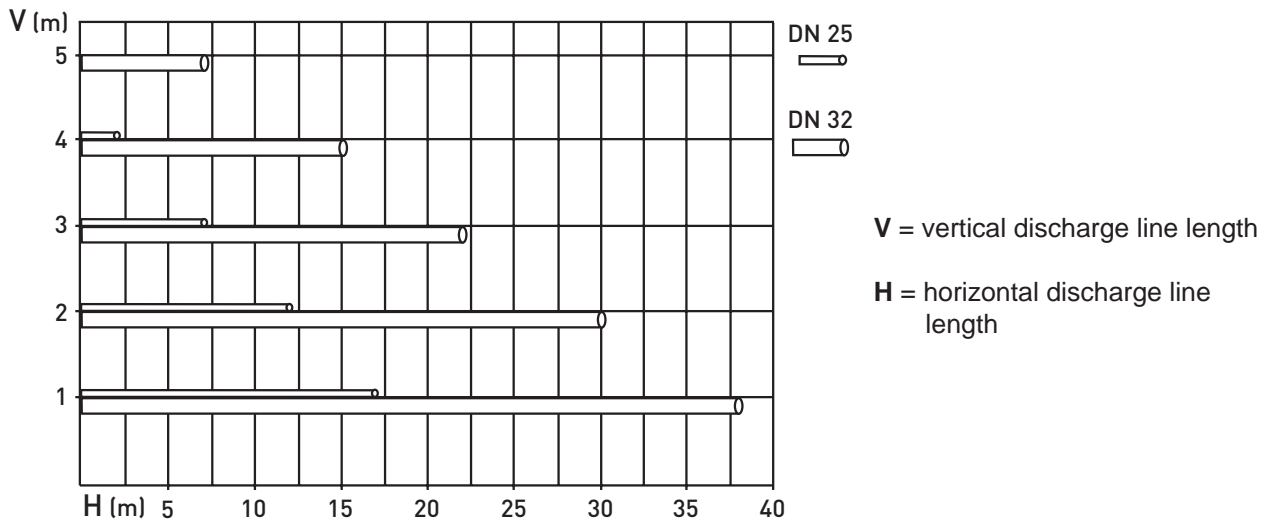

1104-01

Figure 2: Maximum discharge line lengths for the optimum functioning of the unit. Allowance has been made for two 90° bends and Sulzer non-return valves.

### 1.4 Legal regulations DIN and EN covering the use of lifting stations for the pumping of sewage containing faecal matter

Automatic lifting stations are required if the normal water level in the odour-lock of the effluent source lies under the sewer backwash level.

In the case of installations of the size and design of the Piranhamat 100/120, only a single WC, one hand wash basin, one bidet, and one shower tray may be connected. The direct or indirect connection of other effluent sources is not allowed. In addition another WC must be available above the sewer backwash level. If more effluent sources are present then we recommend our Sanimat range.

**ATTENTION** The regulations of DIN 1986/100, EN 12050 and 12056 should be observed!

### 1.5 Accessories

The Piranhamat 100/120 lifting unit is supplied as standard with the following fittings:

- Non-return valve (flap type)
- Hose clamp (x2)
- Rubber cap
- Fixing screw (x2)
- Dowel floor fixing (x2)
- Ground fixing (2)
- \* The version with part No. 07560320 / 07565092 has an additional seal with built-in, non-return valve.

## 1.6. Dimensions (mm)

### NOTE

*As certain European countries e.g. Germany specify a minimum inflow height of 180 mm for the connection port of additional effluent sources, the connection at height 74 mm\* is not available on versions with the part no. 07560310 / 07565091. If exchanging an older model and it is not possible to move the inflow pipe position, then the version with part no. 07560320 / 07565092 with the lower inflow height of 74 mm and the seal with built-in non return valve which is supplied as standard with this version should be used.*

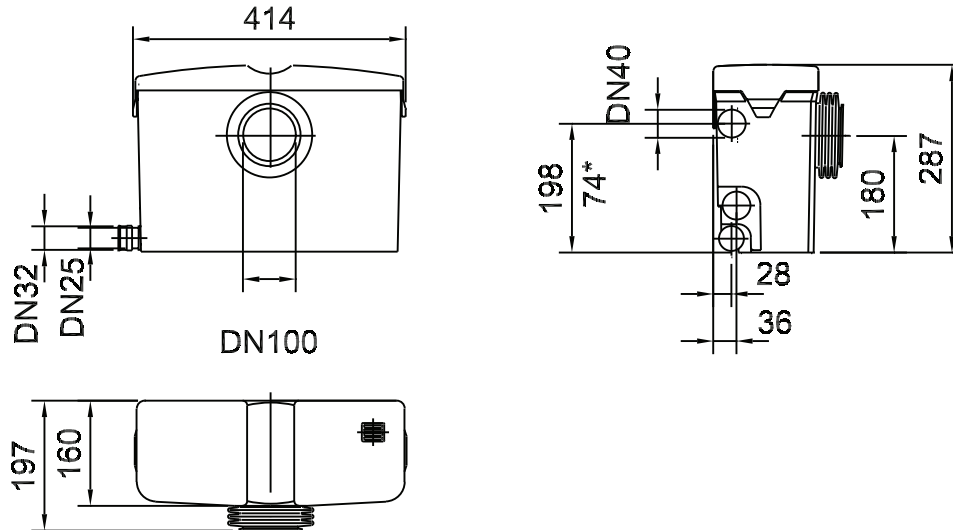

Figure 3: Dimensions of Piranhamat 100/120

1114-00

## 2 Transport



During transport the unit should not be dropped or thrown.



The unit should never be raised or lowered by the power cable.

All relevant safety regulators as well as general good technical practice must be complied with.

## 3 Safety

The general and specific Health and Safety conditions are described in detail in the “Safety Instructions for Sulzer Products Type ABS” booklet. If anything is not clear or you have any questions as to safety make certain to contact the manufacturer Sulzer.

This unit can be used by children aged 8 years and above, and persons with reduced physical, sensory, or mental capabilities, or lack of experience and knowledge, when they have been given supervision or instruction concerning the safe use of the device and understand the hazards involved. Children must not play with the appliance. Cleaning and user maintenance should not be performed by children without supervision.

## 4 Description

The lifting unit of the Piranhamat 100/120 series is supplied ready for installation and has been designed for the pumping of effluent containing faecal matter in accordance with DIN standards.

The pump installed in a lifting unit is equipped with the Sulzer Piranha cutting system and has been designed to pump normal toilet domestic effluent.

On the front side of the unit is located a toilet push-on connection designed for the self-sealing connection of a single WC. In addition, DN 40 inflow ports are located both on the left and right-hand side for connection of a hand wash basin, bidet and a single shower tray.

Piranhamat 120 only: the unit has a built-in acoustic alarm signal that is activated when the water level remains at a high level for more than 30 seconds.

### 4.1 Design of the Piranhamat 100/120 lifting unit

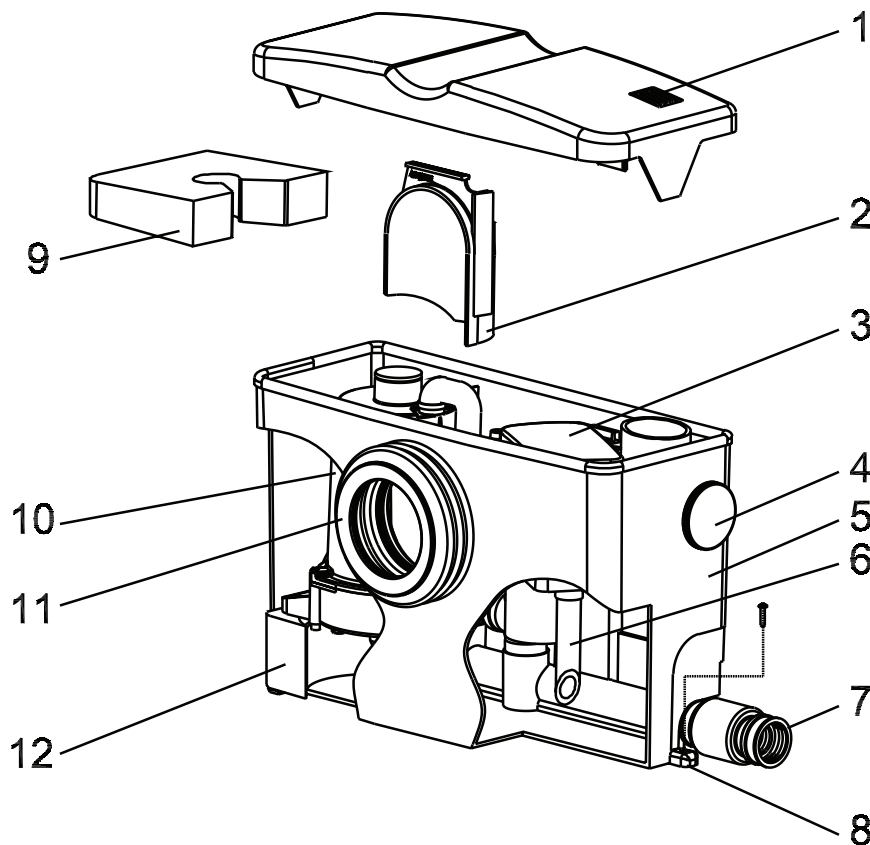

1106-00

Figure 4: Design of the Piranhamat 100/120 lifting unit.

1. Venting by means of carbon filter with the facility for connection of vent line.
2. Inflow deflector plate.
3. Electronic control unit.
4. Connection DN40 for hand wash basin, a bidet or shower tray either on the left-hand or right-hand side of the unit.
5. Tank.
6. Pipe to level control switch.
7. Discharge line connection valve - can be connected to the left-hand or right-hand side of the unit.
8. Tank fixing and flotation prevention.
9. Flotation prevention for the motor.
10. Pump motor with hydraulic section.
11. Inlet port DN100 for direct toilet connection.
12. Support for pump motor.

## 5 Set up and installation of the Piranhamat 100/120

**ATTENTION** *A maximum of a one toilet, one hand wash basin, one bidet and a single shower tray may be simultaneously connected to the Piranhamat 100/120 unit. The WC must be directly connected without the use of an intermediate pipeline to the Piranhamat 100/120 unit.*



The inflow lines from the hand wash basin and the shower tray must have an inflow height such that the lowest part of the inflow line has an inflow height of at least 180 mm. This is to ensure that the inflow lines can discharge fully by gravity, and that back-up cannot occur.

**ATTENTION** *see note under 1.5. (\* version with part no.07500320 / 07565092)*

### 5.1 Installation - inflow side

**ATTENTION** *When installing the discharge line ensure that Section 5.1.1 Discharge line is observed.*

The Piranhamat 100/120 (1) is designed for a direct toilet connection. The Piranhamat 100/120 unit is set up directly behind the toilet. The DN 100 sealing sleeve (3) should be drawn up directly on to the toilet outlet pipe. In order to comply with DIN standards the inflow lines from the hand wash basin, bidet and shower tray must be at least 180 mm above the container base and provision for inflow by gravity must exist in order that these inflow lines will remain clear.

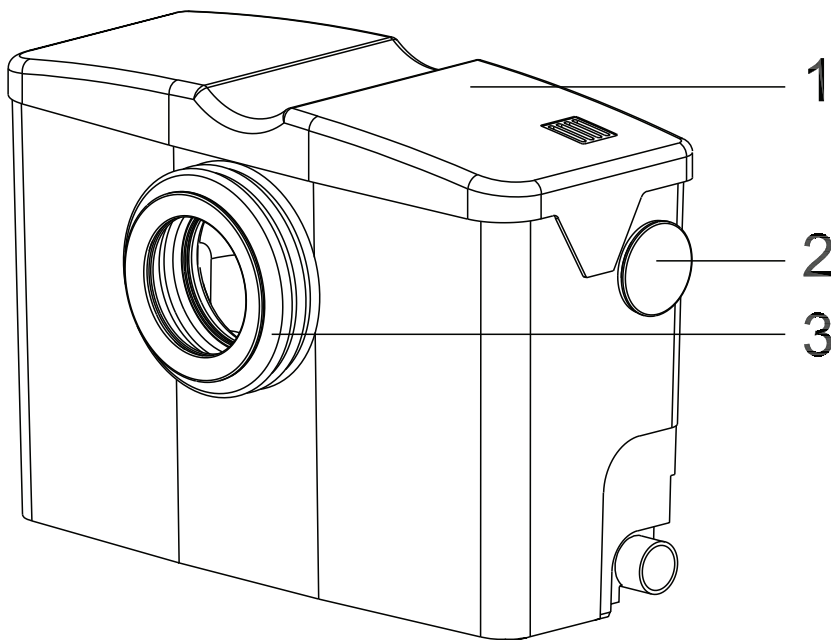

- 1 Piranhamat 100/120
- 2 Connection for a hand wash basin, bidet or shower.
- 3 Sealing sleeve for direct toilet connection.

1108-00

Figure 5: Inflows to the Piranhamat 100/120

**5.1.1 Installation - discharge line**

The discharge line can be connected to the Piranhamat 100/120 (1) from the left (3) or right (4) as required. The discharge port not used should be sealed off with cap (2) and securely tightened using the hose clamp provided.

The non-return valve (5) should be fitted directly to the discharge line (3) or (4) as required and tightened using the hose clamp provided. Ensure that the flap is correctly positioned in the line for horizontal installation.

**NOTE** *The non-return valve can be used for connecting discharge lines of outer diameter of 25 mm and 32 mm.*

Insert the discharge line into the non-return valve (5) and tighten using the clamps provided. Do not insert the discharge line more than 16 mm into the non-return valve as it may push the integrated check valve flap out of position.

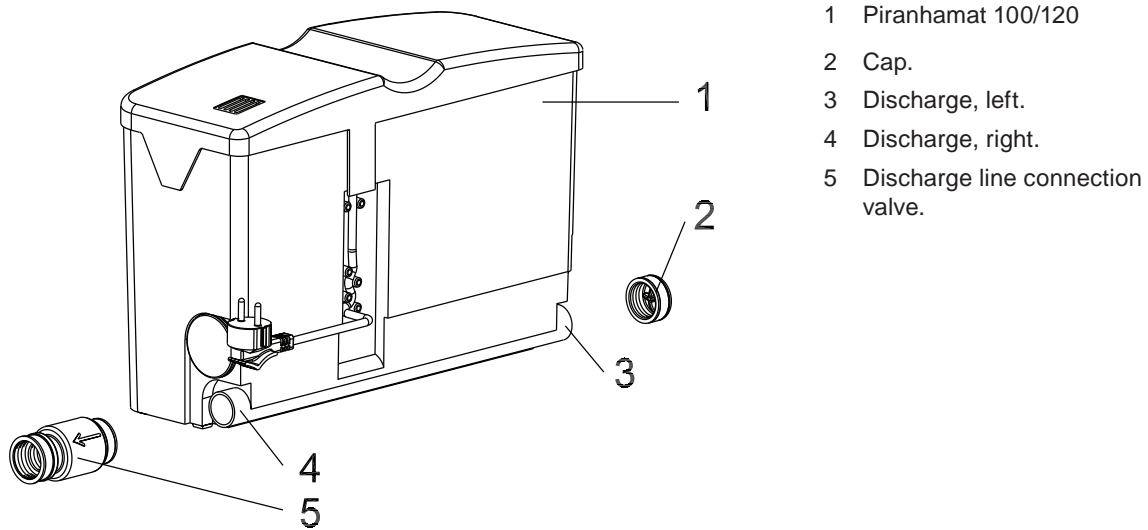

Figure 6: Discharge line connection of Piranhamat 100/120

Install the discharge line (outer diameter 25 or 32 mm) with the aid of a backwash loop (180° bend) and connect it into the sewer line above the sewer backwash level. The flap-type, non-return valve should be fitted direct to the Piranhamat 100/120. When fitting the valve horizontally, the flap must hinge from the top with the arrow pointing down, see "C" below. The arrow on the outside of the housing indicates flow direction. (Regulation DIN 1986).

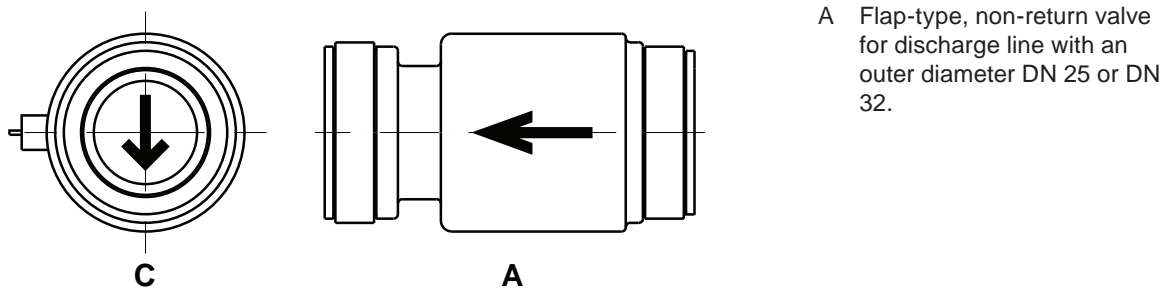

Figure 7: Design of the flap-type, non-return valve.

**ATTENTION** *The discharge line should be laid in such a manner that it is not affected by frost. The discharge line should not be connected to a downpipe. It is not permissible to connect other inflows or discharge lines to the discharge line itself.*

**NOTE** *The non-return valve should be accessible for servicing.*



## 5.1.2 Venting

The venting and aeration of the unit can take place into a room via the activated carbon filter with overflow prevention supplied as standard. A separate vent line (external diameter 25 mm) brought above roof level may be fitted. This is done by removing the screen and inserting a pipe.

## 5.1.3 Connection of hand wash basin, bidet or shower

A hand wash basin or shower is connected by pressing the inflow line (3) into the push-in seal of the upper inlet opening (1) after removal of the plug. Make certain that it is pushed fully home.

**ATTENTION** *The push-in seal must be inserted in such a manner that the pipe retaining shoulder as well as the printed letters "OBEN" point upwards.*

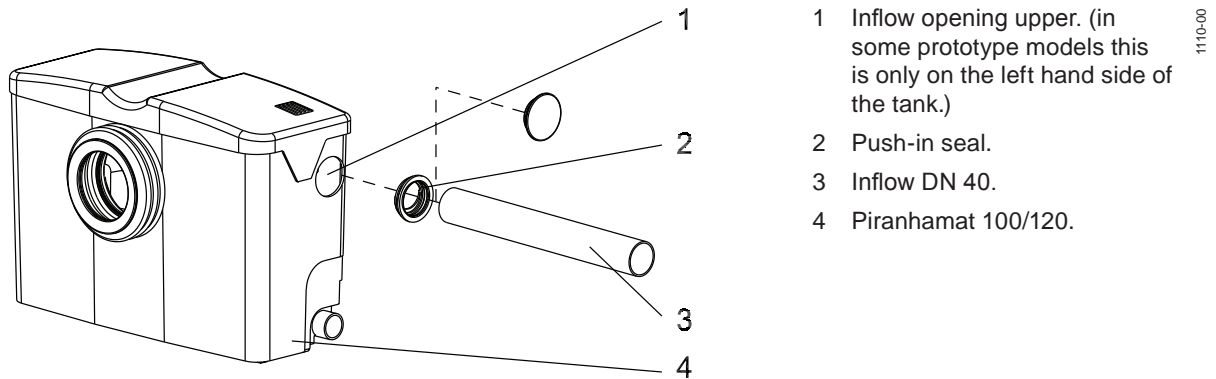

Figure 8: Connection of an inflow line DN40

**ATTENTION** *If exchanging a Piranhamat 100/120 of the new series for one of the older Piranhamat models we recommend that you use the version part no. 07560320 / 07565092 with the lower opening. See note under 1.5.*

## 5.2 Electrical connection



Before commissioning, an expert should check that one of the necessary electrical protective devices is available. Earthing, neutral, earth leakage circuit breakers, etc. must comply with the regulations of the local electricity supply authority and a qualified person should check that these are in perfect order.

**ATTENTION** *The power supply system on site must comply with VDE or other local regulations with regard to cross-sectional area and maximum voltage drop. The voltage stated on the nameplate must correspond to that of the mains*

This unit must be connected to a mains switch which isolates all poles.

All relevant safety regulators as well as general good technical practice must be complied with.

The unit is supplied ready for installation. An earthed socket (in accordance with VDE / Electrical Supply Board guidelines) installed in a correct manner is all that is required.

**ATTENTION** *The Piranhamat 100/120 unit should not be placed in a position where excessive steam or flooding of the complete unit may occur. Should this occur please have the unit thoroughly checked before use.*

**ATTENTION** *The earthed socket should comply with the relevant regulations.*

**NOTE** *Please consult your electrician.*

## 6 Commissioning



The safety hints in the previous sections must be observed!

Before commissioning, the unit should be checked and a functional test carried out. Particular attention should be paid to the following:

- Have the electrical connections been carried out in accordance with regulations?
- Is the tank cover pushed fully home? Unit should only be operated with the cover in the fully home position.
- Is the WC discharge being pumped away quickly?
- Is the run-on time suitable (a slurping noise occurs).

## 7 Maintenance and service



Before commencing any maintenance work the unit should be completely disconnected from the mains by a qualified person and care should be taken that it cannot be inadvertently switched back on.



Servicing must only be carried out by qualified personnel.

### NOTE

***The maintenance hints given here are not designed for “do-it-yourself” repairs as special technical knowledge is required.***

### NOTE

***The Sulzer warranty conditions are only valid provided that any repair work has been carried out in a Sulzer approved workshop and where original Sulzer spare parts have been used.***

### 7.1 Maintenance of the Piranhamat 100/120 lifting unit

- We recommend that the lifting unit be inspected visually every month and its functioning checked
- In addition we recommend that a maintenance contract be concluded with a qualified specialist company.

### USER TIP

***Switching the power supply to the unit OFF and ON will operate the unit manually. This may allow certain blockages to be cleared without dismantling the unit***

### 7.2 General maintenance hints

Sulzer lifting units are reliable quality products each being subjected to careful final inspection.

Lubricated-for-life ball bearings together with monitoring devices ensure optimum reliability, provided that the unit has been connected and operated in accordance with the operating instructions.



To avoid danger if the power cable is damaged, it must be replaced by the manufacturer or its service agent or a similarly qualified person.

### NOTE

***The Sulzer service organisation would be pleased to advise you on any applications you may have and to assist you in solving your pumping problems.***

### NOTE

***A maintenance contract with our service department will guarantee you the best technical service under all circumstances.***

### 7.3 Steps to be taken should a fault occur

### ATTENTION

***Water sources which drain into the Piranhamat 100/120 should not be used should a fault occur.***

### 7.3.1 Piranhamat 100/120 does not work - motor makes a humming noise.

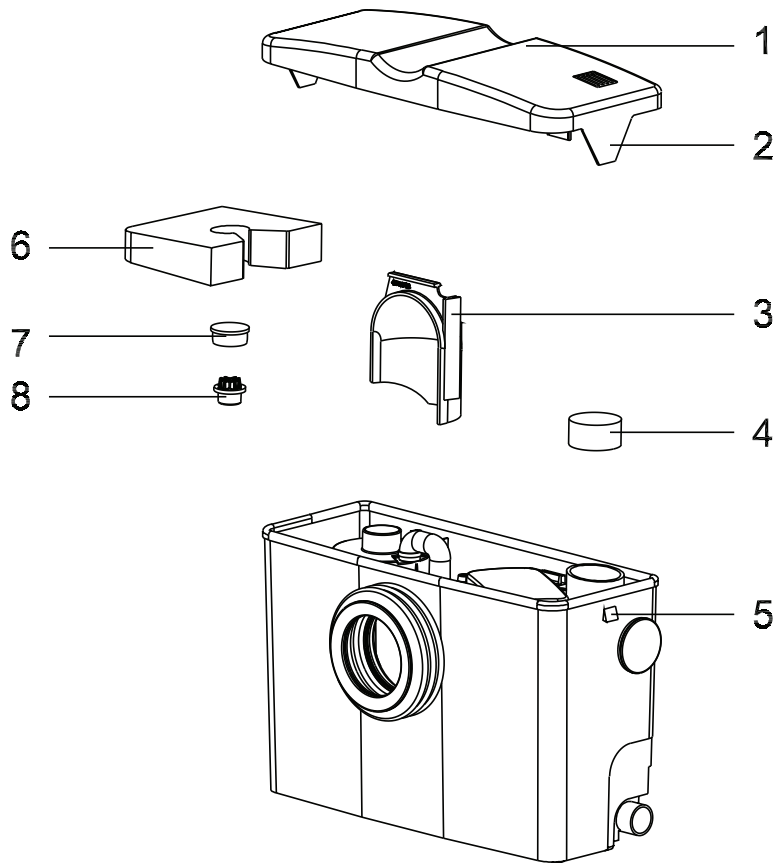

Figure 9: Piranhamat 100/120 opened for maintenance purposes.

- Withdraw plug and ensure that it cannot inadvertently be switched back on.
- Pull the latches (2) on the tank cover (1) lightly to the outside and lift off the cover.
- Remove the float protection (6).
- Withdraw cap (7) from motor housing.
- Unscrew plug screw (8) and clear a possible blockage of the cutting system by rotating the rotorshaft with a screwdriver or electrical drill.
- Withdraw the deflector plate (3) upwards out of the tank and clean the tank.



There is a danger of injury from the cutting tool in the hydraulic system. Do not place your hand in the tank when the rotorshaft is being turned with a screwdriver or drill as in Fig.10.

- Replace the deflector plate (3) back in the tank.
- Screw back in plug screw (8), refit cap (7), replace the float protection (6) and refit the tank cover (1).



The latches (2) must correctly lock into position.

**ATTENTION** The unit should only be used or tested with the top cover correctly in place.

- Carry out functional test.

If the Piranhamat 100/120 still does not work, withdraw plug and call Sulzer Service.

**7.3.2 Piranhamat 100/120 does not function and motor is silent.**

- Withdraw plug and wait approximately 30 seconds.
- After this waiting period push back in the plug.
- Water sources should not be used in this period.

If after this waiting period the Piranhamat 100/120 does not function correctly, then withdraw the plug and call Sulzer Service.

**NOTE** *In the case of any queries, it is essential that the pump type and part number are given.*

**7.3.3 Changing the carbon filter**

**NOTE** *Normally it is only necessary to change the filter if damage has occurred.*

- Press the latches (Fig 9: 2) on the tank cover (Fig 9: 1) lightly to the outside and lift off the tank cover.
- Change the carbon filter (Fig 9: 4).
- Fit tank cover.



The latches must correctly lock into position.

## 7.3.4 Removal of the Piranhamat 100/120

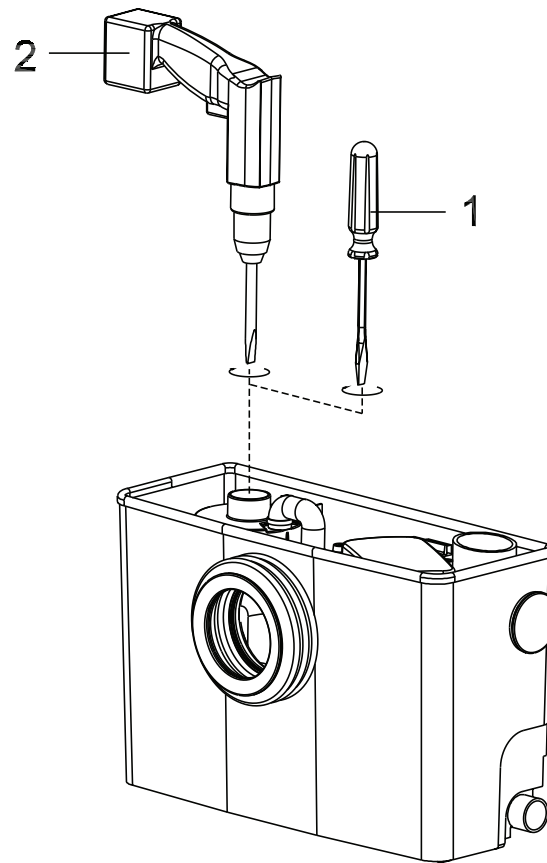

Figure 10: Emptying the tank

Before dismantling the discharge and inflow lines, it is possible to empty the tank by driving the pump by means of an electric drill.

In order to do this:

- Pull the latches (Fig 9: 2) on the tank cover (Fig 9: 1) lightly to the outside and lift off the cover.
- Remove the float protection (Fig 9: 6).
- Withdraw cap (Fig 9: 7) from motor housing.
- Unscrew plug screw (Fig 9: 8) and clear a possible blockage of the cutting system by rotating the rotorshaft with a screwdriver (Fig 10: 1).
- Finally fit a drill with screwdriver attachment (Fig 10: 2).

**NOTE** *By driving the rotorshaft with an electric drill, the hydraulic system of the Piranhamat 100/120 will be operated and the tank emptied.*

- Switch on the drill and allow to run until the tank is empty.
- Screw in plug screw (Fig 9: 8), fit cap (Fig 9: 7), replace float protection and replace tank cover.
- Dismantle discharge and inflow lines.





